

8 Channel Mux/ DeMux Module MDM-15

The MDM-15 is multi-channel WDM Multiplexer or Demultiplexer based on dielectric thin-film filter technology. The module is designed to add or drop 8 channels with ITU grid spacing of 100, 200 or 400GHz. Channels can be dropped with high adjacent channel isolation and all channels are subject to low insertion loss. The MDM-15 can also be configured with an additional band splitting filter to enable device cascading in DWDM systems.

Features

- ▶ Low loss, low PDL
- ▶ High channel isolation
- ▶ Upgradable configuration suitable for scalable system
- ▶ Compact design
- ▶ Telcordia GR-1221 qualified
- ▶ RoHS compliant

Applications

- ▶ Wavelength Mux / Demux
- ▶ Optical Add Drop Multiplexer (OADM)

Model Variations

In Mux and Demux configurations the filter specifications can be tailored to the end-users performance and cost requirements. The "Upgraded" MDM-15 has a common input and output port enabling an express channel for channels which are not to be dropped. Alternatively, the terminated MDM-15 (without express port) realizes lower insertion loss for each channel.

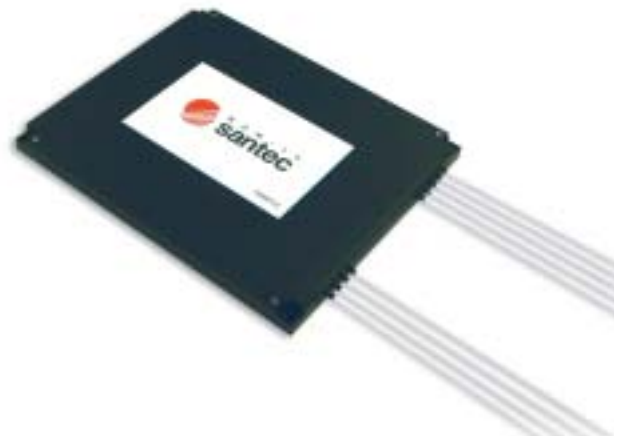

Dimensions

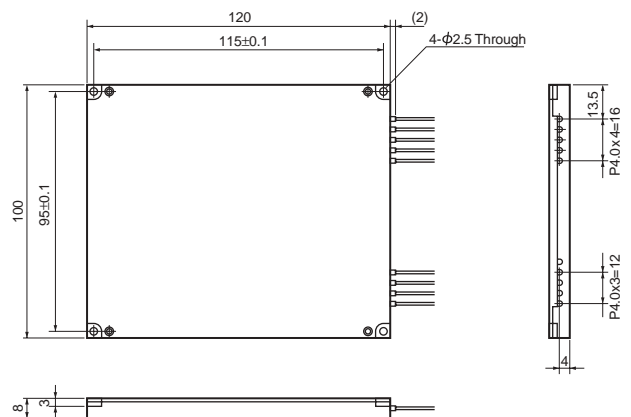

■ 100GHz 8 Channel Mux / DeMux Module

Parameter	Units	Mux	DeMux
Wavelength Range	nm	1520 - 1610	
Channel Spacing	GHz	100	
Number of Channels	dB	8	
Passband	nm	± 0.11	
Flatness	dB	≤ 0.5	
Insertion Loss	dB	≤ 2.8	≤ 3.1
Adjacent Isolation	dB	≥ 12	≥ 25
Non -Adjacent Isolation	dB	-	≥ 40
Directivity	dB	≥ 45	
Return Loss	dB	≥ 45	
Polarization Dependent Loss (PDL)	dB	≤ 0.2	
Polarization Mode Dispersion (PMD)	ps	≤ 0.1	
Max Optical Power	dBm	≤ 23	
Operating Temperature	°C	-5 to +70	
Storage Temperature	°C	-40 to +85	

■ 200 GHz 8 Channel Mux / DeMux Module

Parameter	Units	Mux	DeMux
Wavelength Range	nm	1520 - 1610	
Channel Spacing	GHz	200	
Number of Channels	dB	8	
Passband	nm	± 0.20	
Flatness	dB	≤ 0.5	
Insertion Loss	dB	≤ 2.8	≤ 3.1
Adjacent Isolation	dB	≥ 13	≥ 25
Non -Adjacent Isolation	dB	-	≥ 40
Directivity	dB	≥ 45	
Return Loss	dB	≥ 45	
Polarization Dependent Loss (PDL)	dB	≤ 0.2	
Polarization Mode Dispersion (PMD)	ps	≤ 0.1	
Max Optical Power	dBm	≤ 23	
Operating Temperature	°C	-5 to +70	
Storage Temperature	°C	-40 to +85	

*1 All parameters are specified over operating temperature range.
 *2 Insertion loss per filter includes Ripple and PDL, without connectors.
 *3 Please contact Santec to discuss specific performance requirements.

■ Ordering Code

MDM-15-A-B-C-D/E

A=Channel

7=7ch, 8=8ch

B=Type

10A0=100GHz Add / 10D0=100GHz Drop / 20A0=200GHz Add

20D0=200GHz Drop

C=Fiber Length

10=1.0m, 20=2.0m

D=Connector

00=No Connector, FS=FC-SPC, FA=FC-APC, SS=SC-SPC, SA=SC-APC

MU=MU-SPC, MJ=MUJ-SPC, LC=LC-SPC

E=Center Wavelength of shortest wavelength

(ex) 1552.52nm --->1552.52

www.santec.com E-Mail : sales@santec.com

2002 © SANTEC CORPORATION Santec reserves the right to make changes in equipment design, components or specifications without notice.



SANTEC CORPORATION

5823 Ohkusa-Nenjyozaka, Komaki, Aichi 485-0802, Japan Tel. +81-568-79-1959 Fax +81-568-79-1718

SANTEC U.S.A. CORPORATION

433 Hackensack Ave., Hackensack, NJ, 07601, U.S.A. Toll Free +1-800-726-8321 (santec-1) Tel. +1-201-488-5505 Fax +1-201-488-7702

SANTEC EUROPE LIMITED

Magdalen Centre, Robert Robinson Ave., The Oxford Science Park, Oxford OX4 4GA, U.K. Tel. +44-1865-784960 Fax +44-1865-784961

SANTEC (SHANGHAI) Co., Ltd.

No.800 Zhangyang Road Changhang Tower, Pudong District, Shanghai 200122 China Tel: +86-21-58361261, +86-21-58361262 Fax: +86-21-58361263