

Optical Delay Line Module ODL-330

The ODL-330 module uses an air gap method to generate a delay in the optical signal. The duration of the delay is controlled by adjusting the position of a prism reflector so that the optical distance between the input and the output collimators is varied. The device allows an adjustment of up to 45mm, corresponding to an optical delay of up to 300ps.

Features

- ▶ Simple and unique air gap delay mechanism
- ▶ Max. delay up to 300 psec
- ▶ Low PDL (< 0.1 dB)
- ▶ Low insertion variation (<0.5dB)

Applications

- ▶ Optical time domain effect measurements
- ▶ PMD compensation experiments
- ▶ Time division multiplexing

Principle

Air gap tuning method

A variable optical delay is achieved using the "air gap tuning method" to vary the path length. Coupled with Santec's linear sliding technique, very high accuracy delays of 300 psec are possible using the ODL components.

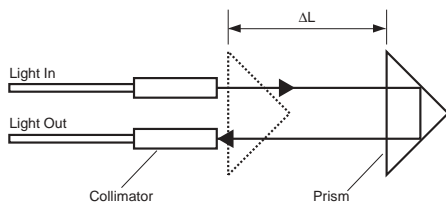

Delay : $t = 2\Delta L/c$, where $2\Delta L$ is the air gap (optical path) difference, c is the speed of light.

Note : "Delay" is a relative value; absolute delay of the module is not precisely specified.



Dimensions

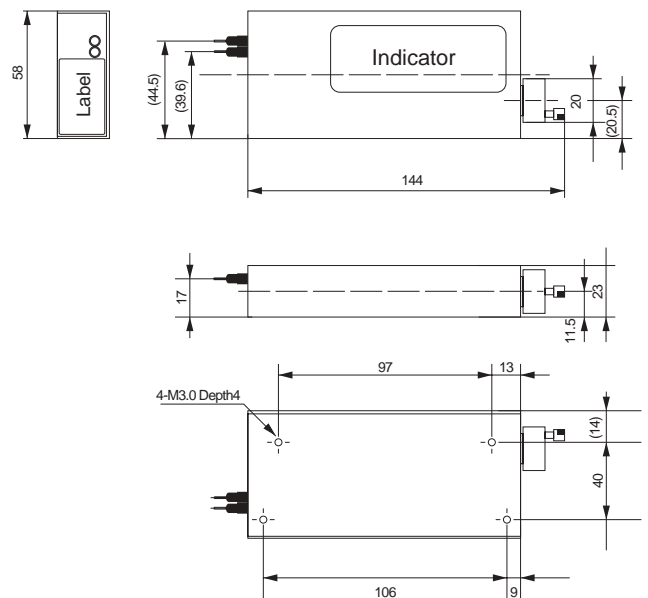

■ Typical Performance

Type	Units	Performance
Wavelength range	nm	1530-1610
Delay range	ps	0 - 300
Resolution	ps	0.2
Insertion loss (max.) (*1)	dB	1.5
Insertion loss variation (*2)	dB	<0.5
PDL (max.)	dB	0.1
Operating temperature	degC	25±5
Size	mm	134 x 58 x 23

*1 When PMF or DSF fiber is specified the insertion loss increases by 0.5dB.

*2 When PMF or DSF fiber is specified the insertion loss variation increases by 0.2dB.

■ Ordering Code

ODL-330 - **A** - **B** - **C** - **D** - **E** - **F**

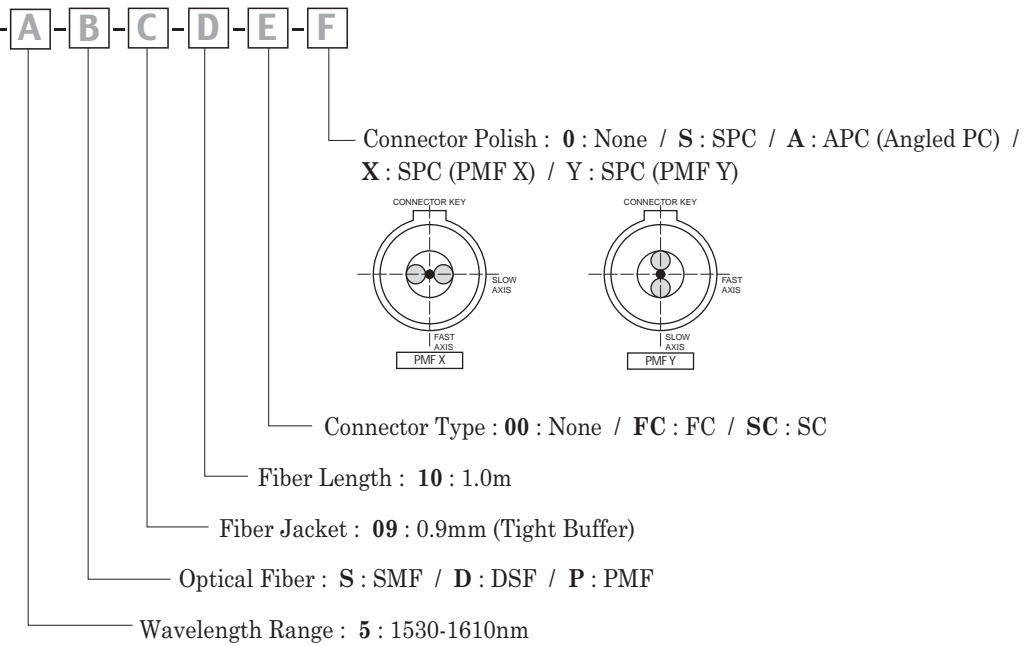

Please contact Santec's customer service to discuss any special requirements.

www.santec.com E-Mail : sales@santec.com

2004 © SANTEC CORPORATION Santec reserves the right to make changes in equipment design, components or specifications without notice.



SANTEC CORPORATION
5823 Ohkusa-Nenjoyozaka, Komaki, Aichi 485-0802, Japan Tel. +81-568-79-1959 Fax +81-568-79-1718

SANTEC U.S.A. CORPORATION
433 Hackensack Ave., Hackensack, NJ, 07601, U.S.A. Toll Free +1-800-726-8321 (santec-1) Tel. +1-201-488-5505 Fax +1-201-488-7702

SANTEC EUROPE LIMITED
Magdalen Centre, Robert Robinson Ave., The Oxford Science Park, Oxford OX4 4GA, U.K. Tel. +44-1865-784960 Fax +44-1865-784961

SANTEC (SHANGHAI) Co., Ltd.
No.800 Zhangyang Road Changhang Tower, Pudong District, Shanghai 200122 China Tel: +86-21-58361261, +86-21-58361262 Fax: +86-21-58361263