

MEMS Attenuator MOVA-1 / 8

Santec's MEMS (Micro Electro Mechanical Systems) based attenuator uses tilting mirror technology. Our MEMS technology is simple and unique MEMS mirror structure for high yield chip production and stable operation as variable optical attenuator. Coupled with laser-welded packaging, this provides both environmental reliability and operational stability design with excellent optical properties. 8 channels array type is compact package and any drive voltage range can be customized as option.



Features

- ▶ Low loss, low PDL
- ▶ Fast response
- ▶ Low power consumption
- ▶ Compact package
- ▶ Proprietary stiction-free structure
- ▶ Excellent anti-shock/vibration performance
- ▶ Bright and dark type available
- ▶ Telcordia GR-1221, GR-63 qualified
- ▶ Custom operating voltage range (8ch array type)

Applications

- ▶ Optical power management
- ▶ WDM channel equalization
- ▶ Gain control for amplifiers
- ▶ Overload protection

Typical Data

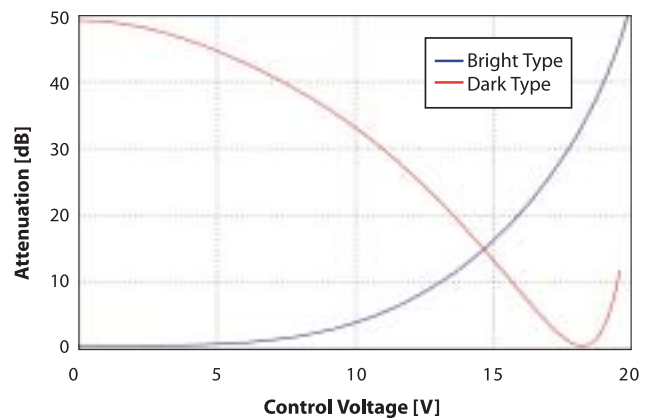

Specifications

Parameter	Unit		Spec	Note
Wavelength Range	-	nm	1530 - 1570	C band
			1570 - 1610	L band
Insertion Loss	Max.	dB	0.8	Excluding Connectors
Max. Attenuation	Max.	dB	30	
PDL	Max.	dB	0.5	@<20dB Attenuation
PMD	Max.	psec	0.1	
Response Time	Max.	msec	20	
Optical Power Handling	Min.	mW	300	
Driving voltage	Max.	V	20	MOVA-1
			7.5	MOVA-8
Operating Temperature	-	°C	-5 to 70	
Power consumption	Max.	mW	20	MOVA-1
			125	MOVA-8
Fiber Length	-	mm	1000±100	0.25mm SMF

Dimensions

MOVA-1

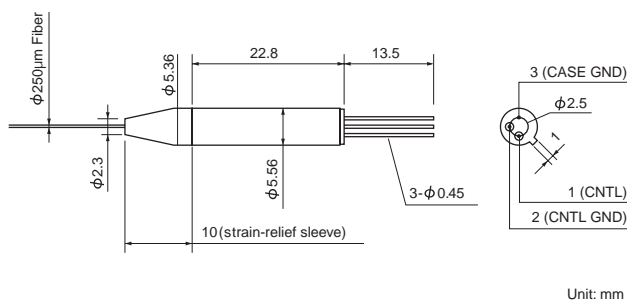

MOVA-8

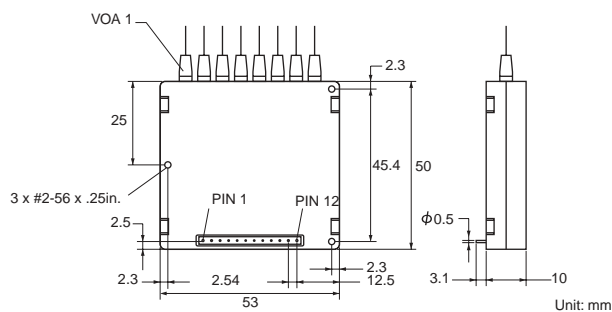

Pin Assignment

Pin#	Function	Pin#	Function
1	Vcc	7	Ch5
2	Ch1	8	GND
3	Ch2	9	Ch6
4	GND	10	Ch7
5	Ch3	11	GND
6	Ch4	12	Ch8

Ordering Code

MOVA - **A** - **B** - **C** - **D**

A = Channel
 B = Activation Type
 C = Wavelength range
 D = Connector Type

1 : Single channel / **8** : 8 channel array

B : Bright type / **D** : Dark type

C : C-band / **L** : L-band

00 : No connector / **FS** : FC-SPC / **FA** : FC-APC / **SS** : SC-SPC /

SA : SC-APC / **MU** : MU-SPC / **MJ** : MUJ-SPC / **LC** : LC-SPC

www.santec.com E-Mail : sales@santec.com

2005 © SANTEC CORPORATION Santec reserves the right to make changes in equipment design, components or specifications without notice.

September, 2007



SANTEC CORPORATION
 5823 Ohkusa-Nenjyozaka, Komaki, Aichi 485-0802, Japan Tel. +81-568-79-1959 Fax +81-568-79-1718

SANTEC U.S.A. CORPORATION
 433 Hackensack Ave., Hackensack, NJ, 07601, U.S.A. Toll Free +1-800-726-8321 (santec-1) Tel. +1-201-488-5505 Fax +1-201-488-7702

SANTEC EUROPE LIMITED
 Magdalen Centre, Robert Robinson Ave., The Oxford Science Park, Oxford OX4 4GA, U.K. Tel. +44-1865-784960 Fax +44-1865-784961

SANTEC (SHANGHAI) Co., Ltd.
 No.800 Zhangyang Road Changhang Tower, Pudong District, Shanghai 200122 China Tel: +86-21-58361261, +86-21-58361262 Fax: +86-21-58361263