

High Power Tunable Laser TSL-210H

The TSL-210H utilizes the latest advances in semiconductor laser technology. Using an external cavity design, the TSL-210H emits over 50mW of optical power over the full tuning range. This eliminates the need for subsequent amplification in many high power applications, and has the advantage of lower noise and significantly lower cost. The laser maintains all the features of Santec's current TSL-210 design, with ease of use and excellent long-term power and wavelength stabilities.



Features

- ▶ >50mW Output Power
- ▶ 1510-1580nm Wavelength Range
- ▶ Stable Output
- ▶ Simple Operation

Applications

- ▶ High power telecommunication R&D and test stations for manufacturing
- ▶ Fibre Optic Sensing

Output Characteristics

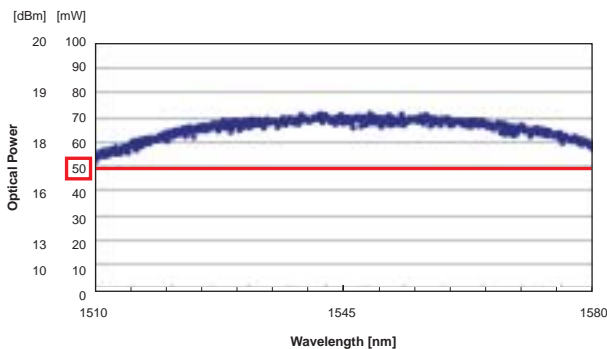

The TSL-210H emits over 50mW of output power over the full wavelength range.

CP-10 Control Pad for TSL-210H

The TSL lasers feature a simple, easy to use front panel interface. The CP-10 enables control of all functions in a compact handheld unit. Up to 128 combinations of wavelength and power can be stored in memory, and wavelength sweeps can be performed with ease and convenience.



Tunable Laser Unit

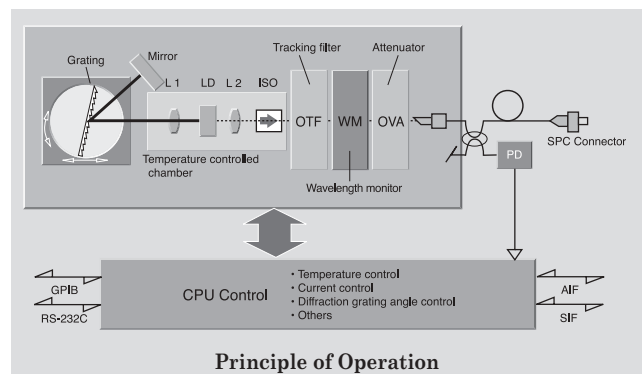

The TSL-210H uses an external cavity design. This provides high wavelength resolution and simple control. Santec's high performance coatings on the laser facet enable the excellent optical properties and high power output to be achieved. A fine-tuning function, variable coherence control and RS-232C and GPIB interfaces are provided as standard.

Specifications

Category	Parameter	Unit	Spec.	Notes
Wavelength Characteristics	Tuning range	nm	1510 to 1580	
	Resolution	nm	0.01	0.001nm with fine tuning
	Accuracy	nm	<±0.2	
	Repeatability	nm	<±0.1	N=50 / *1
	Stability	nm	<±0.01	After a warm-up 1h / *1
	Fine tuning range	GHz	10	
Power Characteristics	Tuning Speed	ms/nm	170	
	Output power	mW	>50	PMF >45
	Accuracy	%	<5	
	Repeatability	dB	<±0.01	N=50 / *1
	Stability	dB	<±0.01	After a warm-up 1h / *1
Spectrum	APC flatness	dB	<±0.2	APC: Automatic Power Control
	Line Width (Coh. OFF)	MHz	<3	*1
	Line Width (Coh. ON)	MHz	200 (typ.)	*1
Environmental Conditions	SSR	dB	>45	*1
	Operating temp.	°C	20 to 30	
	Operating humidity	%	<80	non condensing
	Storage temp.	°C	10 to 40	
Interface	Storage humidity	%	<80	non condensing
	Optical connector	-	FC or SC	
Dimension	Optical Fiber	-	SMF or PMF	
	Width x Height x Depth	mm	210 x 110 x 370	
	Weight	kg	6	

*1 : Measured at center wavelength

Ordering Code

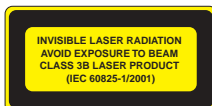
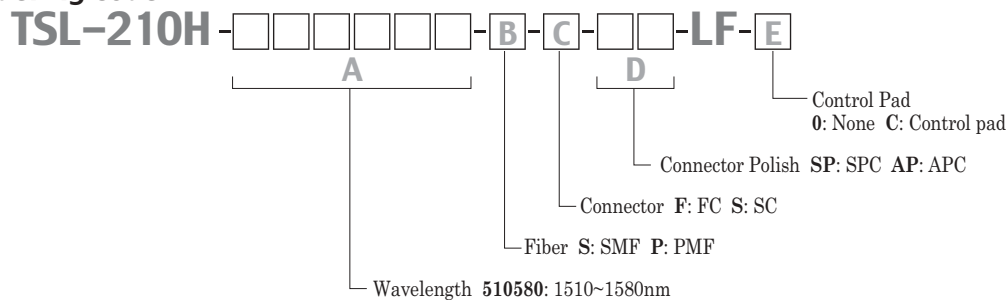

Laser Safety

The TSL-210H is classified as a Class 3B Laser Product according to IEC 60825-1 (Jan. 2001) and 21CFR1040.10 of the FDA. It conforms to the associated safety standards. Injury to the eye can result from viewing the direct beam or a specularly reflected beam.

www.santec.com E-Mail : sales@santec.com

2005 © SANTEC CORPORATION Santec reserves the right to make changes in equipment design, components or specifications without notice.

August 7, 2006



SANTEC CORPORATION

5823 Ohkusa-Nenjoyozaka, Komaki, Aichi 485-0802, Japan Tel. +81-568-79-1959 Fax +81-568-79-1718

SANTEC U.S.A. CORPORATION

433 Hackensack Ave., Hackensack, NJ, 07601, U.S.A. Toll Free +1-800-726-8321 (santec-1) Tel. +1-201-488-5505 Fax +1-201-488-7702

SANTEC EUROPE LIMITED

Magdalen Centre, Robert Robinson Ave., The Oxford Science Park, Oxford OX4 4GA, U.K. Tel. +44-1865-784960 Fax +44-1865-784961

SANTEC (SHANGHAI) Co., Ltd.

No.800 Zhangyang Road Changhang Tower, Pudong District, Shanghai 200122 China Tel: +86-21-58361261, +86-21-58361262 Fax: +86-21-58361263